

### A.8.3 REFRIGERANT SYSTEM DIAGRAM

#### A.8.3.1 INVERTER MODELS Heat pump type

##### 1. PUHZ-HRP•HA2

PUHZ-HRP71VHA2

PUHZ-HRP100VHA2

PUHZ-HRP100YHA2

PUHZ-HRP125YHA2

Unit : mm(inch)

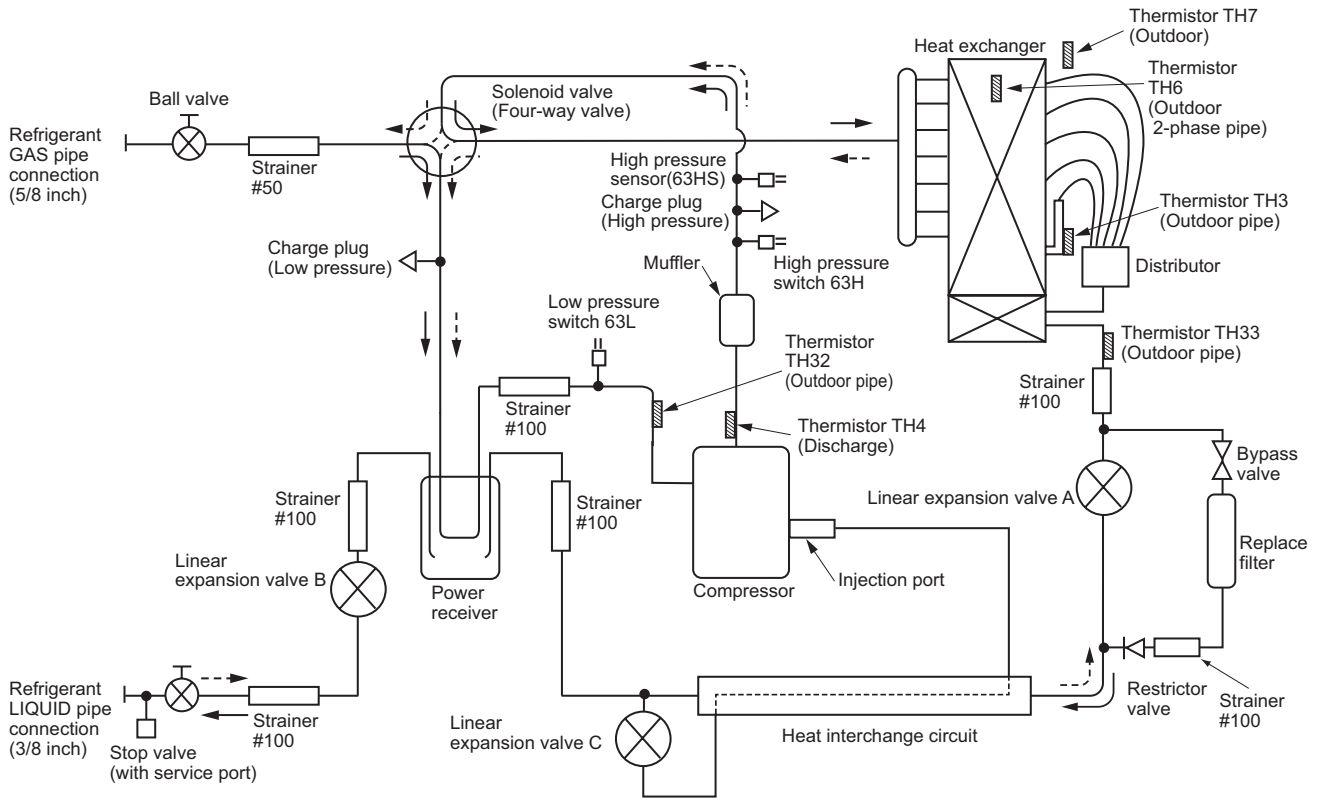
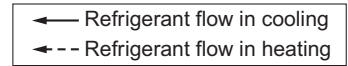

##### 2. PUHZ-RP•HA4/KA

PUHZ-RP35VHA4

PUHZ-RP50VHA4

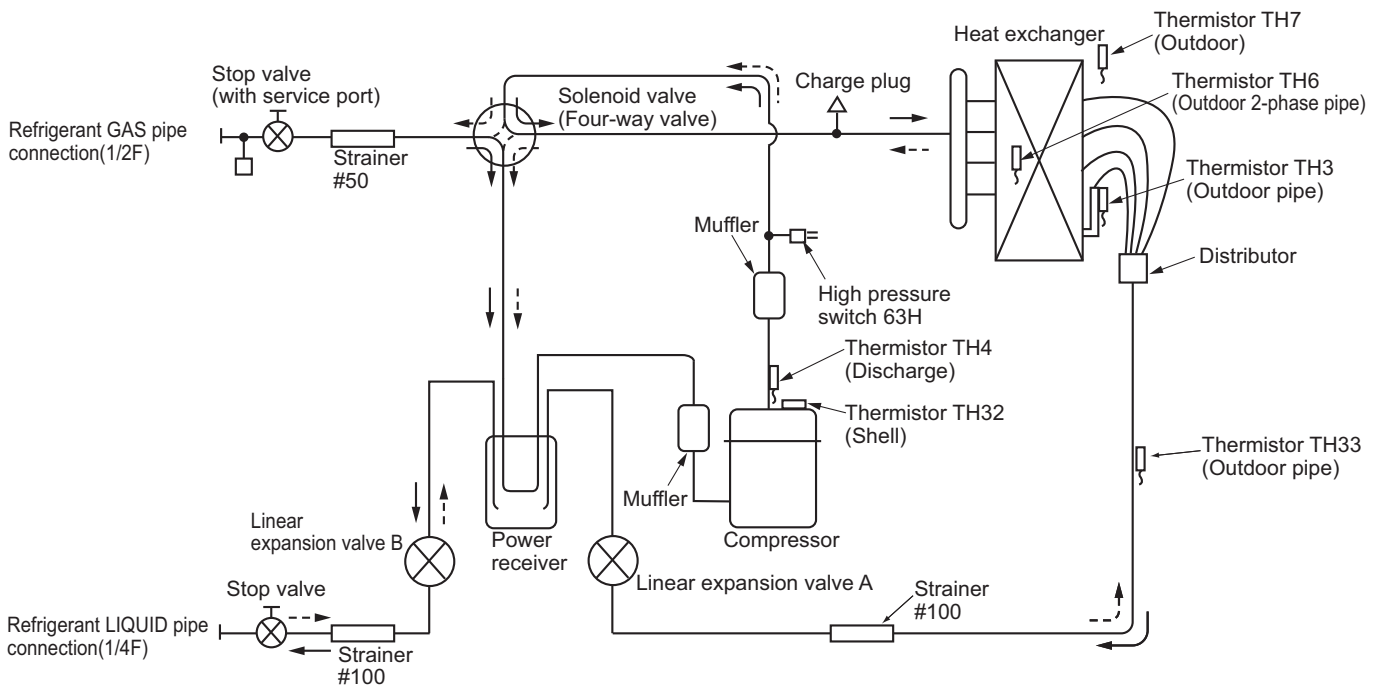

OUTDOOR UNIT REFRIGERANT SYSTEM DIAGRAM