

Domestic hot water / Sanitary pumps

ecocirc[®] E1

Instant hot water at every tap
More comfort · Saves water and energy



ecocirc E1
**Unequaled
economically!**
Only 8 Watt!

- saves 68% electricity compared to a standard circulating pump
- with highly efficient ECM-Technology
- long-lasting, silent operation
- resistant to scale build-up
- maintenance free without blockage, extended service life
- with extremely hard ceramic bearing ball

LAING

simply the best · by design

Domestic hot water / Sanitary pumps

ecocirc® E1

Application

Domestic hot water pumps are installed in the recirculation pipe of the hot water system. By circulating the hot water they ensure that hot water is available instantly even at the tap furthest away from the water heater. Depending on the system design, Ecocirc® E1 pumps can service installations in a single-family house or apartment building.

They conform to the requirements of the German Drinking Water Ordinance and offer effective protection

against Legionella by circulating the drinking water.

The water and energy savings make an important contribution for the environmental protection and the reduction of CO₂.

**ecocirc E1
Unequaled
economically!
Only 8 Watt!**

The Ecocirc® E1 pumps are easy to install. To avoid reverse flow through the pump, a check valve should be used. In combination with a ball valve, the whole pump can be isolated quickly if service should become necessary. To facilitate installation, Ecocirc® E1 pumps are also available with integrated check valve and ball valve. Other areas of applications are solar systems, heat pumps or industrial applications.

The circulators Ecocirc® E1 are the first of its kind to require only 8 Watt of power. This enormous energy saving is made possible by the combination of the spherical motor design invented by Laing and the ECM-Technology.

Model E1



Technical Data

Motor design	electronically commutated shaftless spherical motor with permanent magnet technology
Power consumption	8 Watt
Max. system pressure	10 bar
Electrical connection	230 V, 50 Hz
System temperature	- 10 °C to + 110 °C (non-freezing)
Protection class/Insulation	IP 44/F
Acceptable media	Domestic hot water; heating water, water/glycole mixtures* Other media on request.

*check pump performance for mixtures of 20% or more glycole

Model designation

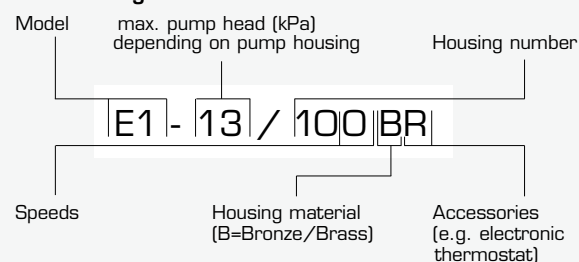

Comparison

Domestic hot water / Sanitary pumps **ecocirc® E1**

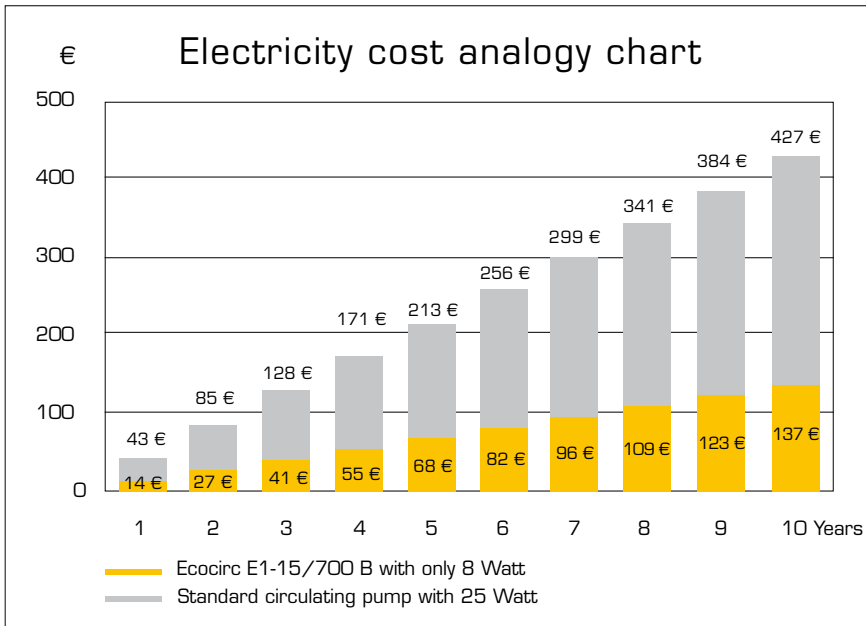

Energy and cost savings

The high-efficiency pump Ecocirc® E1 saves electricity, reduces the CO₂ emission and pays for itself. By comparing the operating expense of a standard circulating pump with 25 Watt and the high-efficiency pump with 8 Watt, the cost savings become quite obvious. The Ecocirc® E1 cost savings are considerable over time.

Compared with a standard circulating pump, the Ecocirc® E1 saves 68% electricity costs!

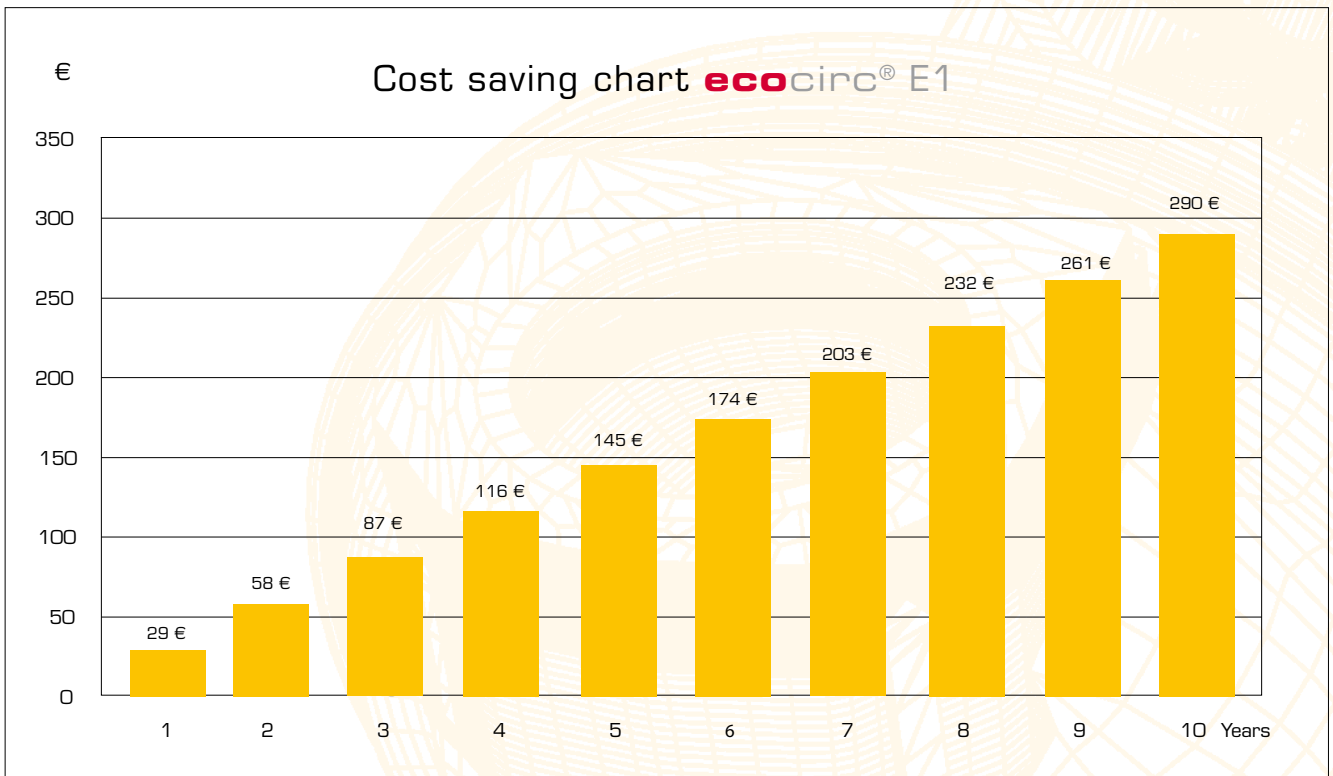

Electricity cost calculation:

Based on electricity costs of 0,1949 €/kWh in Germany and pump operating time of 24 hours/day and 365 days/year. Compare with your local average electricity costs in €/kWh: Belgium 0,1581; Denmark 0,2456; Finland 0,1160; France 0,1211; Greece 0,0720; Ireland 0,1490; Italy 0,2329; Luxembourg 0,1684; Netherlands 0,2130; Norway 0,1643; Poland 0,1184; Portugal 0,1500; Spain 0,1225; Sweden 0,1714; UK 0,1159; (all incl. taxes, referring to the German Federal Statistical Office, January 1st 2007)

Design

Domestic hot water / Sanitary pumps **ecocirc**[®] E1

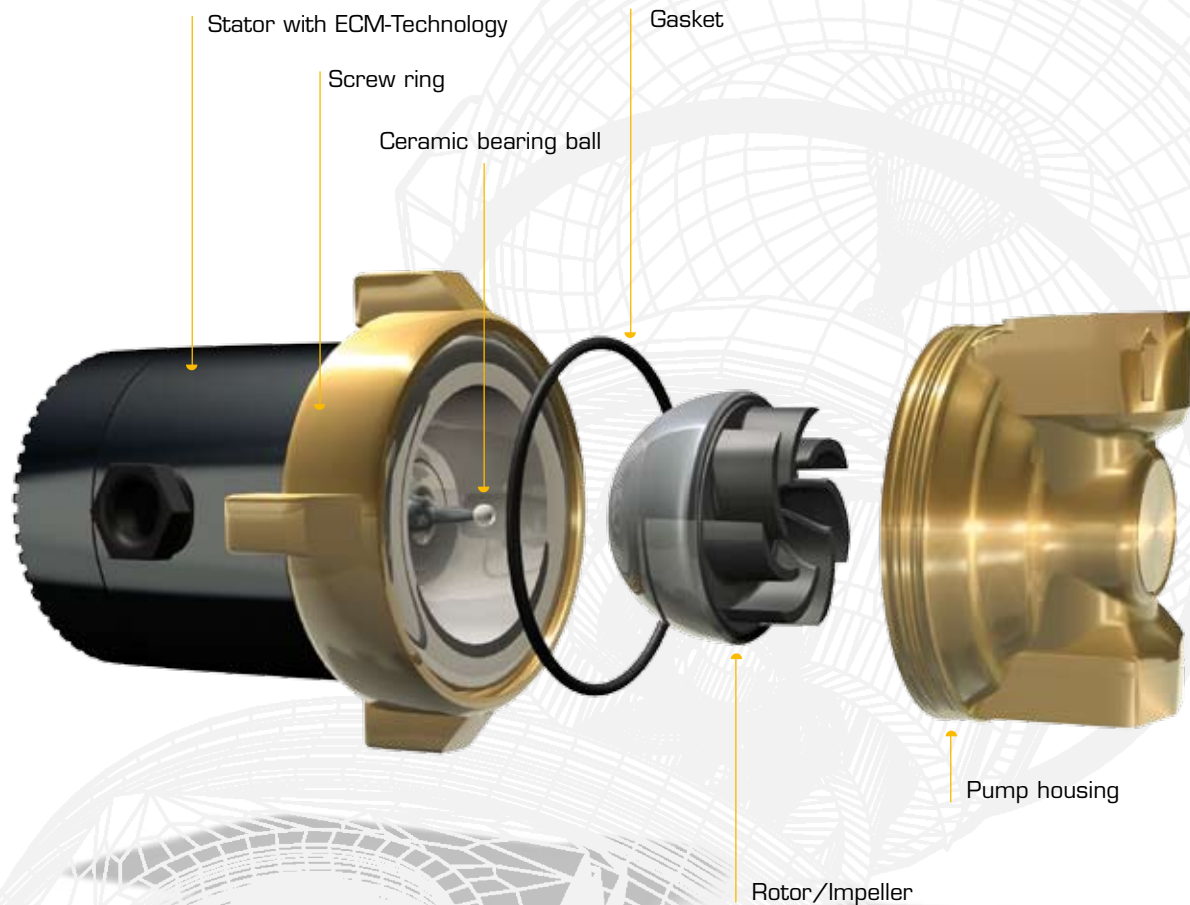

The spherical motor design

Ecocirc[®] DHW pumps are of the spherical motor pump design. The only moving part of this pump type is a spherical rotor/impeller unit which is suspended on an extremely wear resistant ceramic ball. Shaft seals or conventional bearing bushings with a shaft have been eliminated. The only self realigning bearing in the small pump market has many advantages:

The suspension on a ball eliminates any bearing play – even after years of use. The pump therefore will operate quietly for years.

The bearing is self-realigning. It is automatically lubricated and cooled by the pumped media (wet rotor pump). Ecocirc[®] pumps are normally maintenance free.

The rotor is magnetically centered on the bearing and therefore can tilt to avoid blocking by small dirt particles. Even after a long time of shut-off a safe start-up is virtually guaranteed.

The pump can be cleaned easily with typical household cleaner in the unlikely case of scale deposits.

Integrated, stepless scale protection thermostats are optional. These thermostats are used to set a water temperature where the pump shuts off. This also results in further electricity savings.

Energy Efficiency due to ECM-Technology

(electronic commutation with permanent magnetic rotor)

The circulating pumps Ecocirc[®] E1 are high efficiency pumps. ECM-Technology results in significant energy savings with the same performance:

The basis for the higher efficiency is the permanent magnet rotor. The magnetic field required in the rotor does not have to be created while incurring losses, but it is permanently there. A microprocessor installed in the pump creates a rotating magnetic field with variable frequency in the stator coils (electronic commutation), which turns the rotor. The starting torque, and therefore the blockage resistance, when compared with standard circulators, is significantly increased, too.



ecocirc® E1 without check and ball valve

Model	Part number	Pump connection thread	Pump housing length	Electronic control thermostat (20-70°C)	for union fittings	Product category
E1-15/700 B E1-15/700 BR	14 00 001 14 00 003	1/2" female	65 mm 65 mm	•	AV 1/2 x 1/2 AV 1/2 x 1/2	C



ecocirc® E1 with integrated check and ball valve

Model	Part number	Pump connection thread	Pump housing length	Electronic control thermostat (20-70°C)	for union fittings	Product category
E1-13/100 B E1-13/100 BR	14 00 006 14 00 008	1 1/4" male and 1/2" female	110 mm 110 mm	•	AV 5/4 x 3/4 and AV 1/2 x 1/2	C

ecocirc® E1 Replacement motors for models E1



Model	Part number	Replacement motors (incl. two optional gaskets) for ...	Product category
E1-15/000 E1-15/000 R	14 00 081 14 00 083	E1-15/700 B and Laing models S1, competitive pumps Grundfos UP 15-14	C C
E1-11/000	14 00 085	competitive pumps Vortex, Wilo Z15 and Grundfos UP 15 - 13 B	C

ecocirc® E1 Accessories, components and spare parts



Model	Part number	Description	Product category
Others			
RV 1/2"	95 00 001	Brass check valve 1/2" male x 1/2" female	C
KH 1/2"	95 00 020	Brass ball valve chrome plated 1/2" male x 1/4" female	C
Union fittings			
AV 1/2 x 1/2	95 00 024	2 pieces union fittings 1/2" male x 1/2" female	C
AV 5/4 x 3/4	95 00 025	2 pieces union fittings 1 1/4" femal x 3/4" female	C
Replacement rotors			
R-1	95 00 600	Rotor for series E1, incl. gasket	C

Dimensional drawings

Domestic hot water / Sanitary pumps **ecocirc**® E1

all dimensions in mm

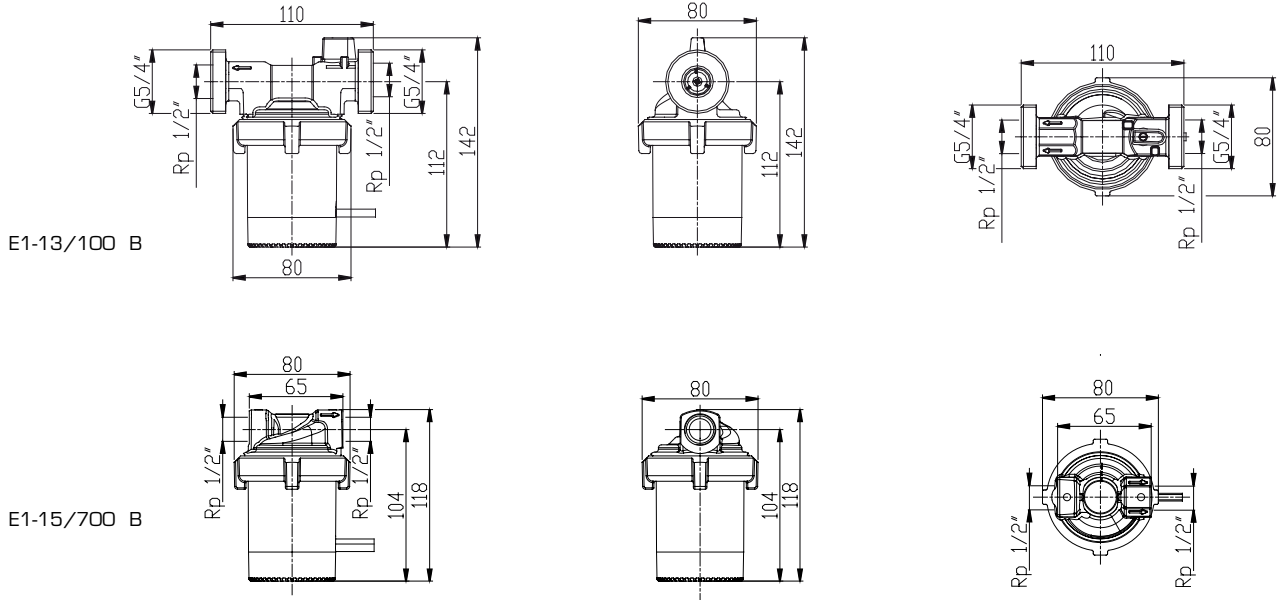

E1-13/100 B

E1-15/700 B

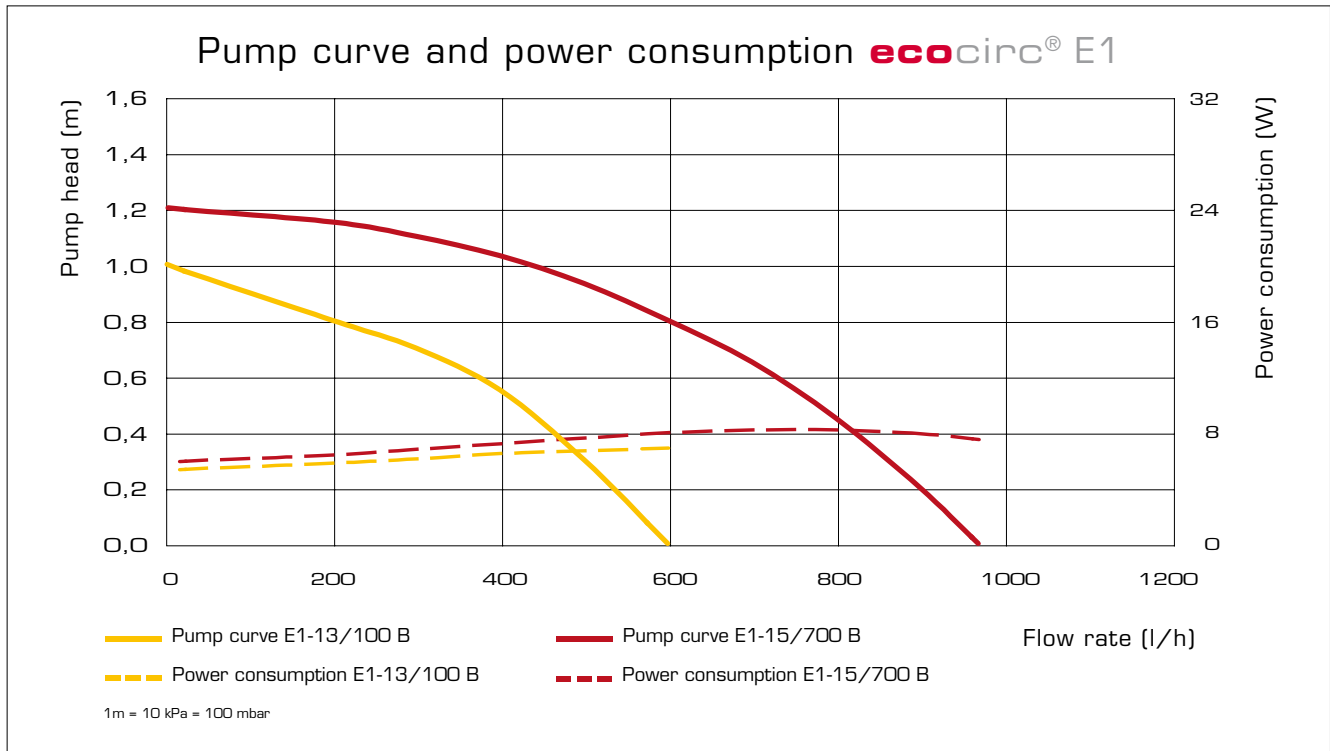

20082007 Subject to change without notice. For environmental's sake printed on chlorine free bleached paper.

